

## Basic Switch

# Z

### General Purpose Basic Switch

- High precision basic switch in a variety of styles
- Wide margins of operating conditions increase the operating speed range
- Available in general purpose and drip-proof types

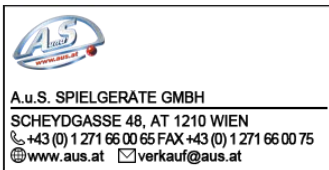

### Ordering Information

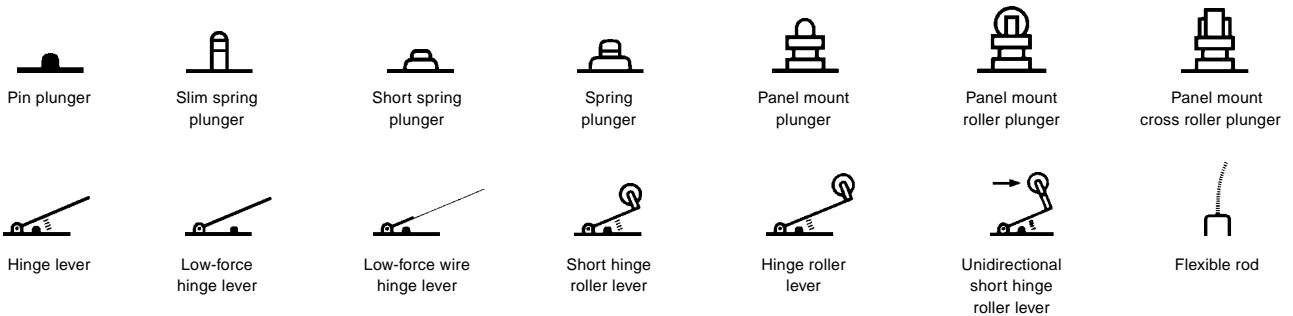

#### GENERAL PURPOSE TYPE

##### Standard

Actuator	Operating Characteristics	Rated Current	Part Number	
			Solder Terminal	Screw Terminal
Pin plunger		15 A	<b>Z-15G</b>	<b>Z-15G-B</b>
Slim spring plunger		15 A	<b>Z-15GS</b>	<b>Z-15GS-B</b>
Short spring plunger	Low OP	15 A	<b>Z-15GD</b>	<b>Z-15GD-B</b>
Panel mount plunger	Middle OP	15 A	<b>Z-15GQ</b>	<b>Z-15GQ-B</b>
Panel mount roller plunger		15 A	<b>Z-15GQ22</b>	<b>Z-15GQ22-B</b>
Panel mount cross roller plunger		15 A	<b>Z-15GQ21</b>	<b>Z-15GQ21-B</b>
Hinge lever	Low OF	15 A	<b>Z-15GW</b>	<b>Z-15GW-B</b>
Low-force hinge lever		15 A	<b>Z-15GW4</b>	<b>Z-15GW4-B</b>
Short hinge roller lever		15 A	<b>Z-15GW22</b>	<b>Z-15GW22-B</b>
Hinge roller lever	Parallel	15 A	<b>Z-15GW2</b>	<b>Z-15GW2-B</b>
Unidirectional short hinge roller lever	Low OF	15 A	<b>Z-15GW2277</b>	<b>Z-15GW2277-B</b>

**GENERAL PURPOSE TYPE**

**High-sensitivity**

Actuator	Operating Characteristics	Rated Current	Part Number	
			Solder Terminal	Screw Terminal
Pin plunger		15 A	—	<b>Z-15H-B</b>
Low-force hinge lever		15 A	—	<b>Z-15HW24-B</b>
Low-force, wire hinge lever	Low OF	15 A	<b>Z-15HW78</b>	<b>Z-15HW78-B</b>
Short hinge roller lever		15 A	—	<b>Z-15HW22-B</b>

**DRIP-PROOF TYPE**

**Standard**

Actuator	Operating Characteristics	Rated Current	Contact Gap	Part Number	
				Solder Terminal	Screw Terminal
Slim spring plunger		15 A	0.5 mm	<b>Z-15GS55</b>	<b>Z-15GS55-B</b>
Short spring plunger		15 A	0.5 mm	<b>Z-15GD55</b>	<b>Z-15GD55-B</b>
Spring plunger	Middle OP	15 A	0.5 mm	<b>Z-15GK55</b>	<b>Z-15GK55-B</b>
	High OP	15 A	0.5 mm	<b>Z-15GK355</b>	<b>Z-15GK355-B</b>
Panel mount plunger	Middle OP	15 A	0.5 mm	<b>Z-15GQ55</b>	<b>Z-15GQ55-B</b>
Panel mount roller plunger		15 A	0.5 mm	—	<b>Z-15GQ2255-B</b>
Panel mount cross roller plunger		15 A	0.5 mm	—	<b>Z-15GQ2155-B</b>
Hinge lever	Low OF	15 A	0.5 mm	<b>Z-15GW55</b>	<b>Z-15GW55-B</b>
Short hinge roller lever		15 A	0.5 mm	<b>Z-15GW2255</b>	<b>Z-15GW2255-B</b>
Hinge roller lever	Parallel	15 A	0.5 mm	<b>Z-15GW255</b>	<b>Z-15GW255-B</b>
Flexible rod	High OF	15 A	0.5 mm	<b>Z-15GNJ55</b>	<b>Z-15GNJ55-B</b>

**DRIP-PROOF TYPE**

**High-sensitivity**

Actuator	Operating Characteristics	Rated Current	Contact Gap	Part Number	
				Solder Terminal	Screw Terminal
Panel mount plunger	Middle OP	15 A	0.25 mm	—	<b>Z-15HQ55-B</b>
Flexible rod	High OF	15 A	0.25 mm	—	<b>Z-15HNS55-B</b>

Note: For smaller mounting hole types, please consult OMRON.

**■ BASIC CONTACT FORM**

Type	Contact gap	Features
General purpose	H: 0.25 mm (high sensitivity)	Pin plunger and lever types available. Drip-proof and flexible rod types are also available.
	G: 0.5 mm (standard)	
Drip-proof	H: 0.25 mm (high sensitivity)	The pin plunger is sealed from the other switch mechanisms by a resilient rubber, and the case and cover are sealed by adhesive so that the switch is resistant to humidity, oil and dust. The degree of protection conforms to IEC IP63.
	G: 0.5 mm (standard)	

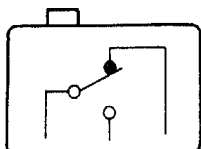
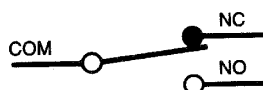

Basic Contact form

# Specifications

## Standard type (except flexible rod types)

Contact gap	Rated voltage	Non-inductive load (A)				Inductive load (A)				Inrush current (A)	
		Resistive load		Lamp load		Inductive load		Motor load			
		NC	NO	NC	NO	NC	NO	NC	NO	NC	NO
G,H	125 VAC	15 (10)	—	3	1.5	15 (10)	—	5	2.5	30 max.	15 max.
	250 VAC	15 (10)	—	2.5	1.25	15 (10)	—	3	1.5		
	500 VAC	10	—	1.5	0.75	6	—	1.5	0.75		
G	8 VDC	15	—	3	1.5	15	—	5	2.5	30 max.	15 max.
	14 VDC	15	—	3	1.5	10	—	5	2.5		
	30 VDC	6	—	3	1.5	5	—	5	2.5		
	125 VDC	0.5	—	0.5	0.5	0.05	—	0.05	0.05		
	250 VDC	0.25	—	0.25	0.25	0.03	—	0.03	0.03		
H	8 VDC	15	—	3	1.5	15	—	5	2.5	30 max.	15 max.
	14 VDC	15	—	3	1.5	10	—	5	2.5		
	30 VDC	2	—	2	1.4	1	—	1	1		
	125 VDC	0.4	—	0.4	0.4	0.03	—	0.03	0.03		
	250 VDC	0.2	—	0.2	0.2	0.02	—	0.02	0.02		

## Standard flexible rod types

Rated voltage	Non-inductive load (A)				Inductive load (A)				Inrush current (A)	
	Resistive load		Lamp load		Inductive load		Motor load			
	NC	NO	NC	NO	NC	NO	NC	NO	NC	NO
125 VAC	15	—	2	1	7	—	2.5	2	30 max.	15 max.
250 VAC	15	—	1	0.5	5	—	1.5	1		
8 VDC	15	—	2	1	7	—	3	1.5		
14 VDC	15	—	2	1	7	—	3	1.5		
30 VDC	2	—	2	1	1	—	1	0.5		
125 VDC	0.4	—	0.4	0.4	0.03	—	0.03	0.03		
250 VDC	0.2	—	0.2	0.2	0.02	—	0.02	0.02		

## ■ CONSTRUCTION

### Drip-proof type

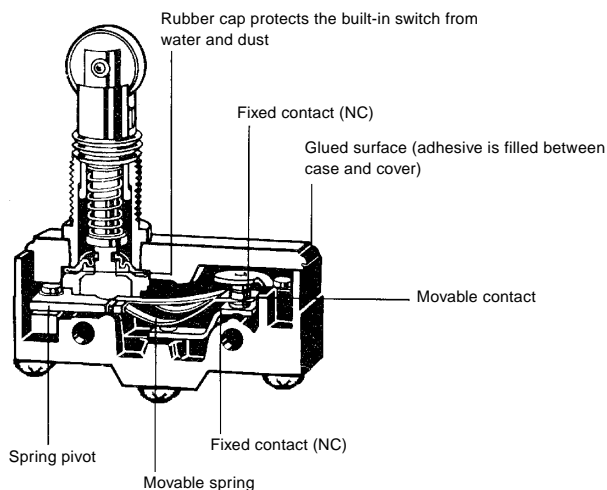

## Characteristics

		Standard (except flexible rod types)	Standard flexible rod types (coil spring and steel wire type)
Operating speed		0.01 mm to 1 m/second (see note 2)	1 mm to 1 m/second
Operating frequency	Mechanical	240 operations/min.	120 operations/min.
	Electrical	20 operations/min.	20 operations/min.
Insulation resistance		100 MΩ min. (at 500 VDC)	
Contact resistance		50 mΩ max. (initial)	15 mΩ max. (initial)
Dielectric strength (VAC)	G contact gap model	1,000 VAC, 50/60 Hz for 1 minute between terminals of same polarity	
	H contact gap model	600 VAC, 50/60 Hz for 1 minute	
		2,000 VAC, 50/60 Hz for 1 minute between current carrying metal parts and ground and between each terminal and non-current carrying metal parts	
Vibration	Malfunction	10 to 55 Hz, 1.5 mm double amplitude (see note 4)	10 to 20 Hz, 1.5 mm double amplitude
Shock	Mechanical durability	1,000 m/s <sup>2</sup> min. (approx. 100 g)	
	Malfunction	300 m/s <sup>2</sup> min. (approx. 30 g) (see note 3)	50 m/s <sup>2</sup> min. (approx. 5 g)
Ambient temperature	Standard types	-25° to 80°C (with no icing)	
	Drip-proof types	-15° to 80°C (with no icing)	
Humidity	Standard types	35% to 85% RH	
	Drip-proof types	35% to 95% RH	
Service life	Mechanical	G, H contact gap models 20,000,000 operations min. (see note 4)	1,000,000 operations min.
	Electrical	G, H contact gap models 500,000 operations min. (see note 2)	100,000 operations min.
Weight		Approx. 22 to 58 g	Approx. 42 to 48 g

- Note: 1. Data shown are of initial value.  
 2. Apply to the pin plunger models or the pin plunger of the lever models.  
 3. Apply to Z-15G.  
 4. Apply to the pin plunger models.

### ■ ACCESSORIES (order separately)

#### Operating Characteristics (when used with Z-15)

Characteristics	ZAA-1 w/Z-15G-B	ZAA-2 w/Z-15G-B
OF max.	500 g	500 g
RF min.	170 g	170 g
PT max.	—	—
OT min.	12.7 mm	12.7 mm
MD max.	2.2 mm	2.2 mm
FP max.	34.5 mm	46.1 mm
OP	28.9±1.6 mm	40.4±1.6 mm

#### Terminal enclosures - Standard models

Material	Mounting method	For solder terminal	For screw terminal	Remarks
Phenolic resin	Side mounting	AP-A	AP-B	—
Metal	Side mounting	AP1-A	AP1-B	Use in conjunction with AP-A and AP-B
Polyvinyl chloride	Side mounting	AP-Z	AP-Z	Excels in safety and dust-proofing property

■ CHARACTERISTIC DATA

Mechanical service life  
Z-15G

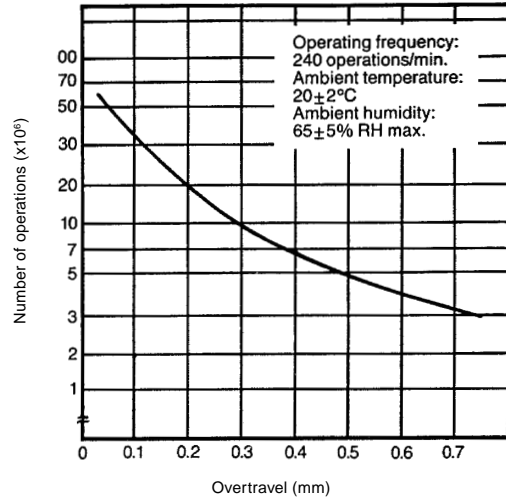

Electrical service life  
Z-15G

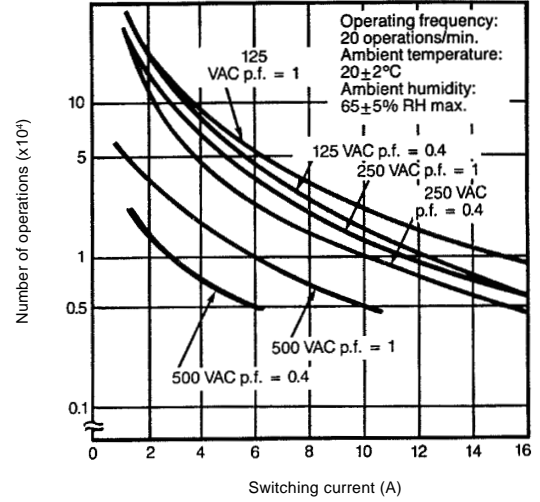

# Dimensions

Unit: mm (inch)

## Z-15G-B, Z-15H-B

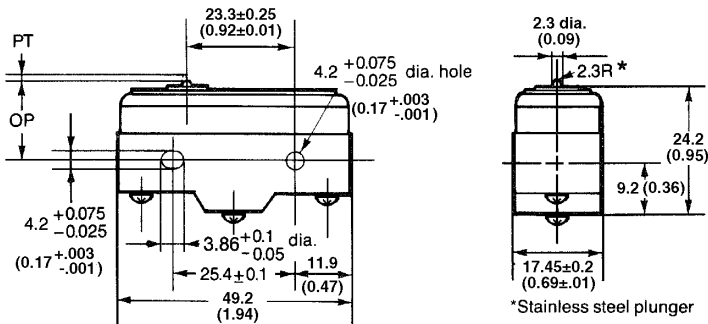

Operating characteristics	Z-15G-B	Z-15H-B
OF	250 to 350 g	200 to 280 g
RF min.	114 g	114 g
PT max.	.4 mm (0.02)	.3 mm (0.01)
OT min.	.13 mm (0.01)	.13 mm (0.01)
MD max.	.05 mm (0.002)	.025 mm (0.001)
OP	15.9 ± 0.4 mm (0.63 ± 0.02)	15.9 ± 0.4 mm (0.63 ± 0.02)

## Z-15GS-B

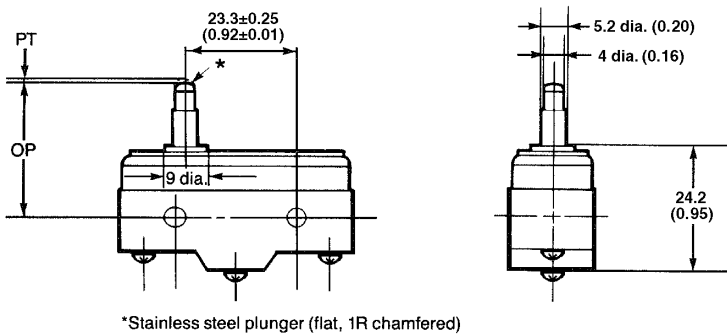

Operating characteristics	Z-15GS-B
OF	250 to 350 g
RF min.	114 g
PT max.	0.4 mm (0.02)
OT min.	1.6 mm (0.06)
MD max.	0.05 mm (0.002)
OP	28.2 ± 0.5 mm (1.1 ± 0.02)

\*Stainless steel plunger (flat, 1R chamfered)

## Z-15GD-B

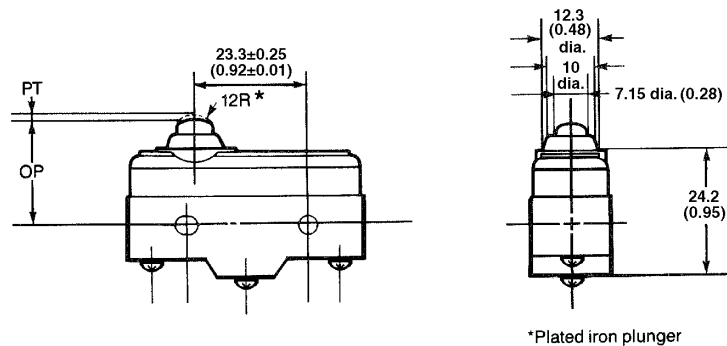

Operating characteristics	Z-15GD-B
OF	250 to 350 g
RF min.	114 g
PT max.	0.4 mm (0.02)
OT min.	1.6 mm (0.06)
MD max.	0.05 mm (0.002)
OP	21.5 ± 0.5 mm (0.85 ± 0.02)

\*Plated iron plunger

- Note: 1. Unless otherwise specified, a tolerance of ± 0.4 mm applies to all dimensions.  
 2. For smaller diameter mounting holes, please consult OMRON.  
 3. All drawings show the switches with screw terminals. For solder terminals, remove the "-B" from the end of the part number.

## Z-15GQ-B

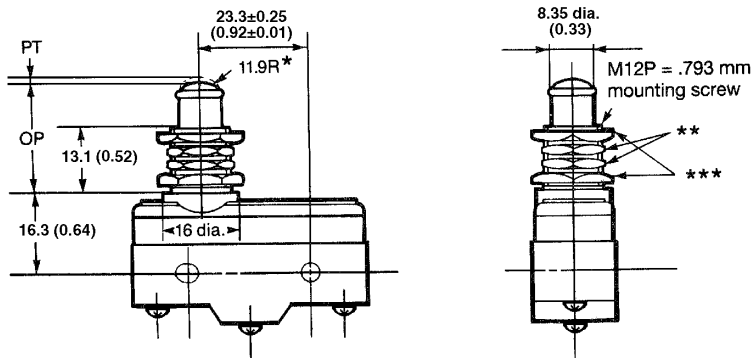

- \*Stainless steel plunger
- \*\*Two hexagonal nuts (2 t x 14 width across flats)
- \*\*\*Two lock nuts (2 t x 15.6 width across flats)

Operating characteristics	Z-15GQ-B
OF	250 to 350 g
RF min.	114 g
PT max.	0.4 mm (0.02)
OT min.	5.5 mm (0.22)
MD max.	0.05 mm (0.002)
OP	21.8 ± 0.8 mm (0.86 ± 0.03)

## Z-15GQ22-B

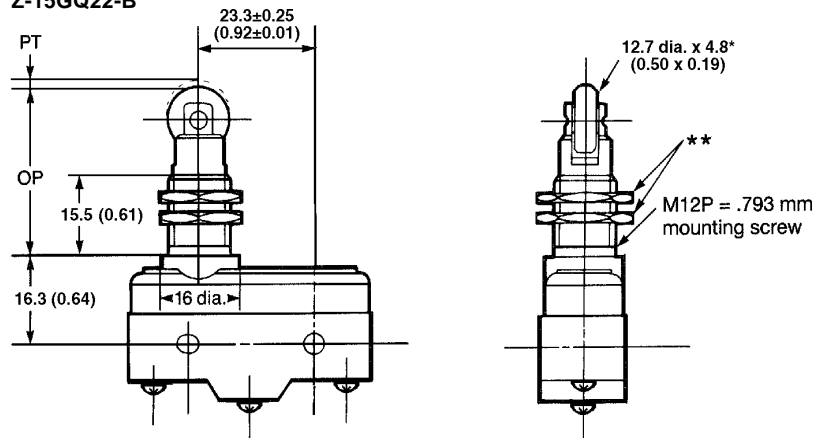

- \*Stainless steel roller
- \*\*Two hexagonal nuts (3 t x 17 width across flats)

Operating characteristics	Z-15GQ22-B
OF	250 to 350 g
RF min.	114 g
PT max.	0.4 mm (0.02)
OT min.	3.58 mm (0.14)
MD max.	0.05 mm (0.002)
OP	33.4 ± 1.2 mm (1.31 ± 0.05)

## Z-15GQ21-B

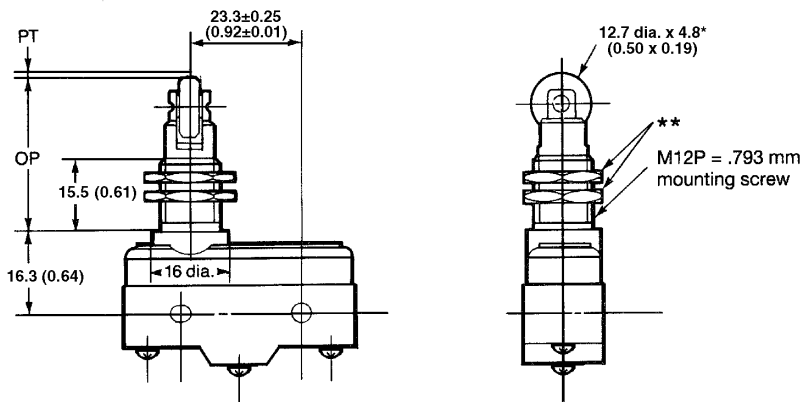

- \*Stainless steel roller
- \*\*Two hexagonal nuts (3 t x 17 width across flats)

Operating characteristics	Z-15GQ21-B
OF	250 to 350 g
RF min.	114 g
PT max.	0.4 mm (0.02)
OT min.	3.58 mm (0.14)
MD max.	0.05 mm (0.002)
OP	33.4 ± 1.2 mm (1.31 ± 0.05)

- Note: 1. Unless otherwise specified, a tolerance of ± 0.4 mm applies to all dimensions.  
 2. For smaller diameter mounting holes, please consult OMRON.  
 3. All drawings show the switches with screw terminals. For solder terminals, remove the "B" from the end of the part number.

Unit: mm (inch)

**Z-15GW-B**

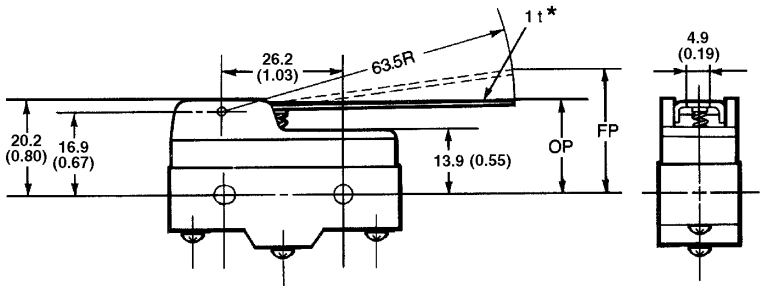

\*Stainless steel lever

Operating characteristics	Z-15GW-B
OF max.	70 g
RF min.	14 g
OT min.	5.6 mm (0.22)
MD max.	1.27 mm (0.05)
FP max.	28.2 mm (1.11)
OP	19 ± 0.8 mm (0.75 ± 0.03)

**Z-15GW4-B**

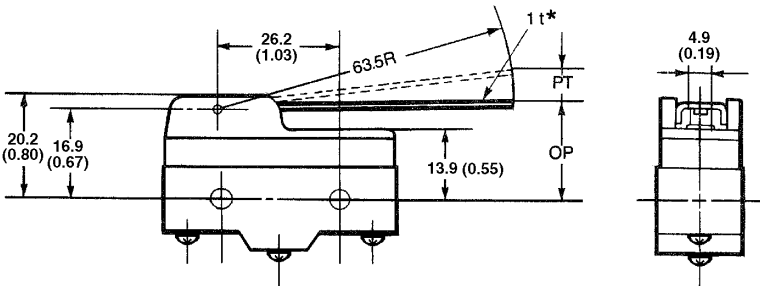

\*Stainless steel lever

Operating characteristics	Z-15GW4-B
OF max.	28 g
RF min.	3.5 g
PT max.	10 mm (0.39)
OT min.	5.6 mm (0.22)
MD max.	1.27 mm (0.05)
OP	19 ± 0.8 mm (0.75 ± 0.03)

**Z-15HW24-B**

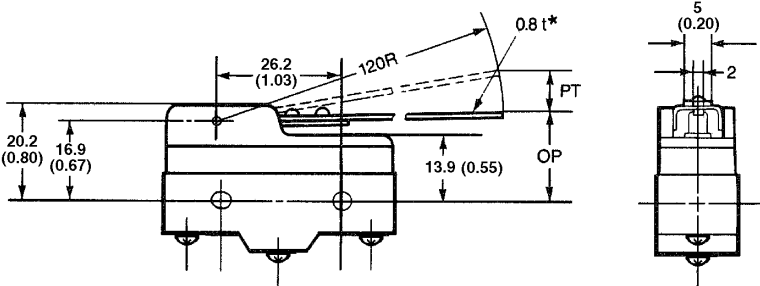

\*Stainless steel lever

Operating characteristics	Z-15HW24-B
OF max.	6 g
RF min.	0.5 g
PT max.	19.8 mm (0.78)
OT min.	10 mm (0.39)
MD max.	2 mm (0.08)
OP	19.8 ± 1.6 mm (0.75 ± 0.03)

**Z-15HW78-B**

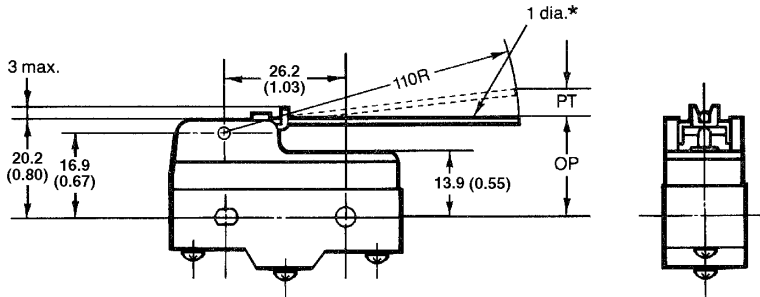

\*Stainless steel wire lever

Operating characteristics	Z-15HW78-B
OF max.	4 g
RF min.	0.3 g
PT max.	10 mm (0.39)
OT min.	6 mm (0.24)
MD max.	3 mm (0.12)
OP	20 ± 1 mm (0.79 ± 0.04)

Note: 1. Unless otherwise specified, a tolerance of ± 0.4 mm applies to all dimensions.  
 2. For smaller diameter mounting holes, please consult OMRON.  
 3. All drawings show the switches with screw terminals. For solder terminals, remove the "-B" from the end of the part number.

## Z-15GW22-B, Z-15HW22-B

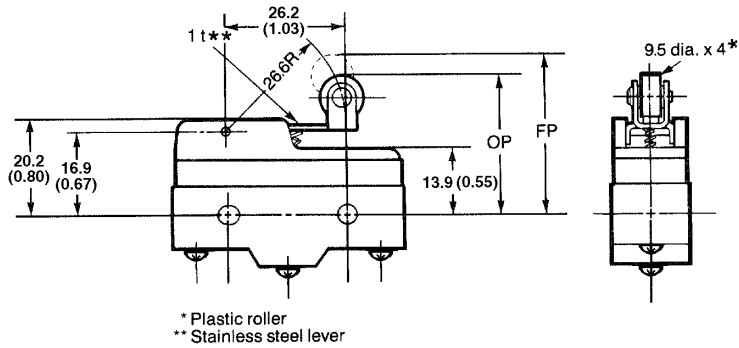

Operating characteristics	Z-15GW22-B	Z-15HW22-B
OF max.	160 g	150 g
RF min.	42 g	42 g
OT min.	2.4 mm (0.09)	2.4 mm (0.09)
MD max.	0.5 mm (0.02)	0.45 mm (0.02)
FP max.	32.5 mm (1.28)	32.5 mm (1.28)
OP	30.2 ± 0.4 mm (1.19 ± 0.02)	30.2 ± 0.4 mm (1.19 ± 0.02)

## Z-15GW2-B

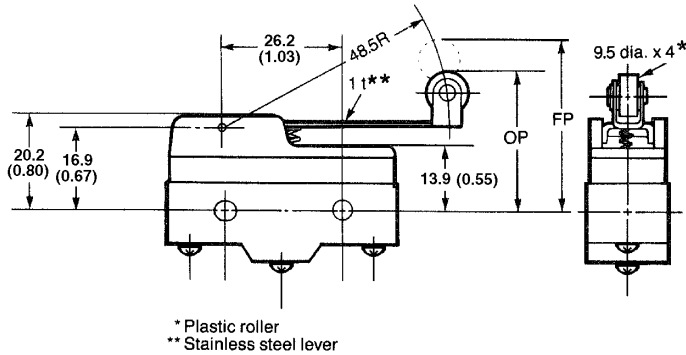

Operating characteristics	Z-15GW2-B
OF max.	100 g
RF min.	22 g
OT min.	4 mm (0.16)
MD max.	1.02 mm (0.04)
FP max.	36.5 mm (1.44)
OP	30.2 ± 0.8 mm (1.19 ± 0.03)

## Z-15GW2277-B

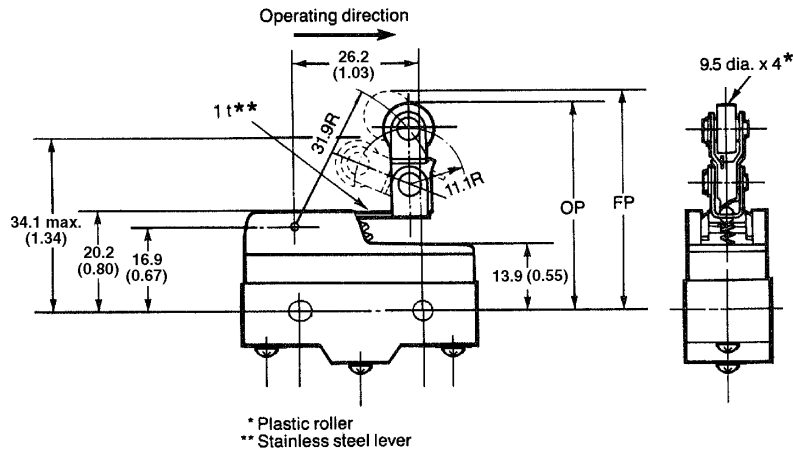

Operating characteristics	Z-15GW2277-B
OF max.	170 g
RF min.	42 g
OT min.	2.4 mm (0.09)
MD max.	0.51 mm (0.02)
FP max.	43.6 mm (1.72)
OP	41.3 ± 0.8 mm (1.63 ± 0.03)

- Note: 1. Unless otherwise specified, a tolerance of  $\pm 0.4$  mm applies to all dimensions.  
 2. For smaller diameter mounting holes, please consult OMRON.  
 3. All drawings show the switches with screw terminals. For solder terminals, remove the "-B" from the end of the part number.

Unit: mm (inch)

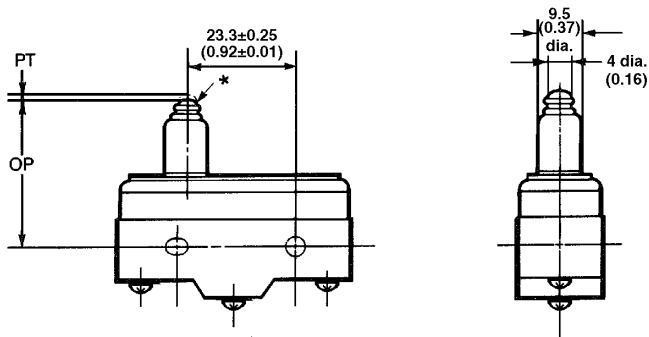
**Z-15GS55-B**\*Stainless steel plunger  
(flat, 1R chamfered)

Operating characteristics	Z-15GS55-B
OF max.	540 g
RF min.	114 g
PT max.	1.9 mm (0.07)
OT min.	1.6 mm (0.06)
MD max.	0.06 mm (0.002)
OP	28.2 ± 0.5 mm (1.11 ± 0.02)

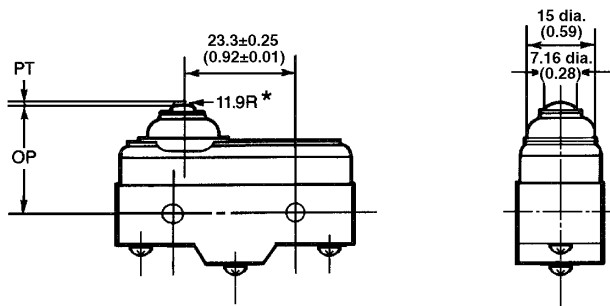
**Z-15GD55-B**

\*Stainless steel plunger

Operating characteristics	Z-15GD55-B
OF max.	540 g
RF min.	114 g
PT max.	1.8 mm (0.07)
OT min.	1.6 mm (0.06)
MD max.	0.06 mm (0.002)
OP	21.5 ± 0.5 mm (.85 ± 0.02)

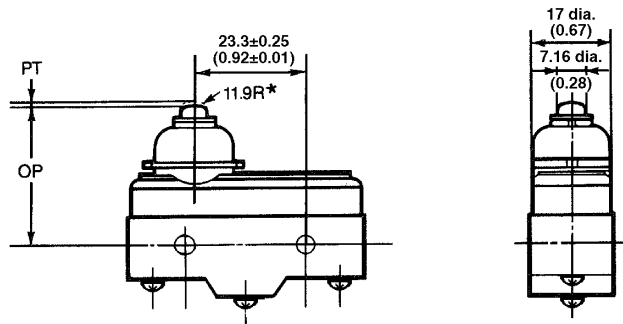
**Z-15GK55-B**

\*Stainless steel plunger

Operating characteristics	Z-15GK55-B
OF max.	540 g
RF min.	114 g
PT max.	2.3 mm (0.09)
OT min.	1.6 mm (0.06)
MD max.	0.06 mm (0.002)
OP	28.2 ± 0.5 mm (1.11 ± 0.02)

- Note: 1. Unless otherwise specified, a tolerance of ± 0.4 mm applies to all dimensions.  
 2. For smaller diameter mounting holes, please consult OMRON.  
 3. All drawings show the switches with screw terminals. For solder terminals, remove the "-B" from the end of the part number.

## Z-15GK355-B

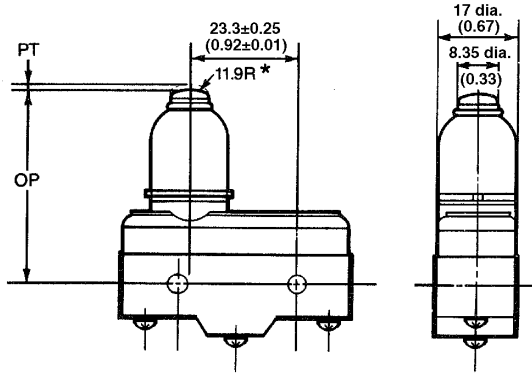

\*Stainless steel plunger

Operating characteristics	Z-15GK355-B
OF max.	540 g
RF min.	114 g
PT max.	2.4 mm (0.09)
OT min.	3.5 mm (0.14)
MD max.	0.06 mm (0.002)
OP	37.8 ± 1.2 mm (1.49 ± 0.05)

## Z-15GQ55-B, Z-15HQ55-B

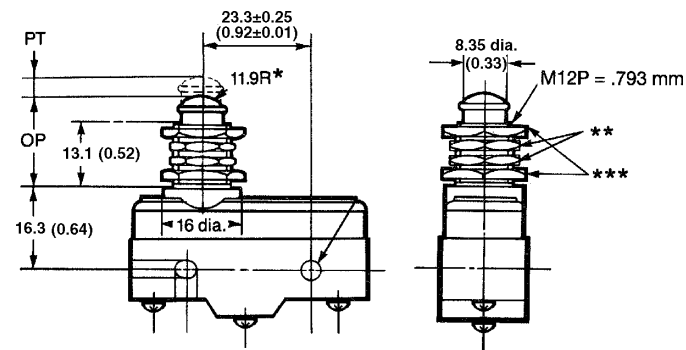

\* Stainless steel plunger  
 \*\* Two hexagonal nuts (2 t x 14 width across flats)  
 \*\*\* Two lock nuts (2 t x 15.6 width across flats)

Operating characteristics	Z-15GQ55-B	Z-15GH55-B
OF max.	540 g	400 g
RF min.	114 g	114 g
PT min.	1.8 mm (0.07)	1.7 mm (0.07)
OT min.	5.5 mm (0.22)	5.5 mm (0.22)
MD max.	0.06 mm (0.002)	0.04 mm (0.002)
OP	21.8 ± 0.8 mm (0.86 ± 0.03)	21.8 ± 0.8 mm (0.86 ± 0.03)

## Z-15GQ2255-B

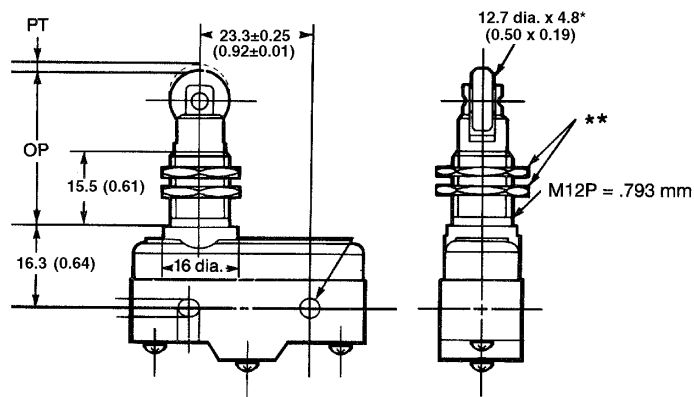

\* Stainless steel roller  
 \*\* Two hexagonal nuts (3 t x 17 width across flats)

Operating characteristics	Z-15GQ2255-B
OF max.	540 g
RF min.	114 g
PT max.	1.8 mm (0.07)
OT min.	3.58 mm (0.14)
MD max.	0.06 mm (0.002)
OP	33.4 ± 1.2 mm (1.31 ± 0.05)

Note: 1. Unless otherwise specified, a tolerance of ± 0.4 mm applies to all dimensions.

2. For smaller diameter mounting holes, please consult OMRON.

3. All drawings show the switches with screw terminals. For solder terminals, remove the "B" from the end of the part number.

Unit: mm (inch)

**Z-15GQ2155-B**

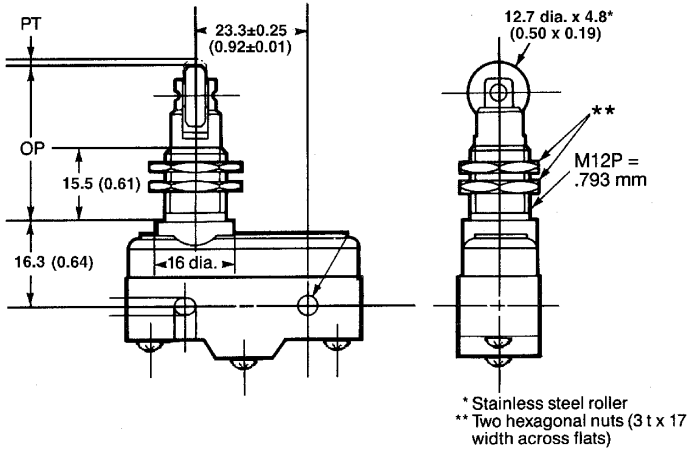

Operating characteristics	Z-15GQ2155-B
OF max.	540 g
RF min.	114 g
PT max.	1.8 mm (0.07)
OT min.	3.58 mm (0.14)
MD max.	0.06 mm (0.002)
OP	33.4 ± 1.2 mm (1.31 ± 0.05)

**Z-15GW55-B**

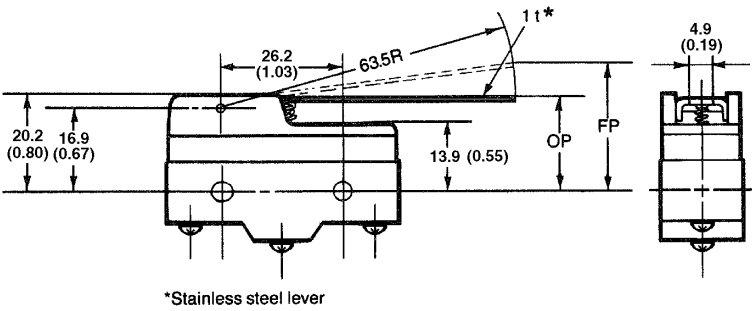

Operating characteristics	Z-15GW55-B
OF max.	100 g
RF min.	14 g
OT min.	5.6 mm (0.22)
MD max.	2 mm (0.08)
FP max.	28.2 mm (1.11)
OP	19 ± 0.8 mm (0.75 ± 0.03)

**Z-15GW2255-B**

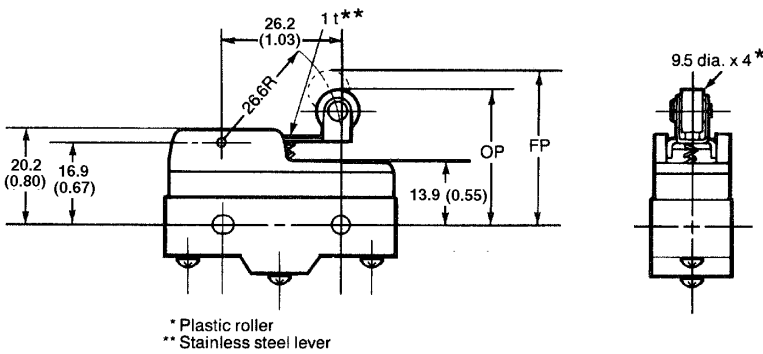

Operating characteristics	Z-15GW2255-B
OF max.	200 g
RF min.	42 g
OT min.	2.44 mm (0.10)
MD max.	0.8 mm (0.03)
FP max.	32.9 mm (1.30)
OP	30.2 ± 0.4 mm (1.19 ± 0.02)

**Z-15GW255-B**

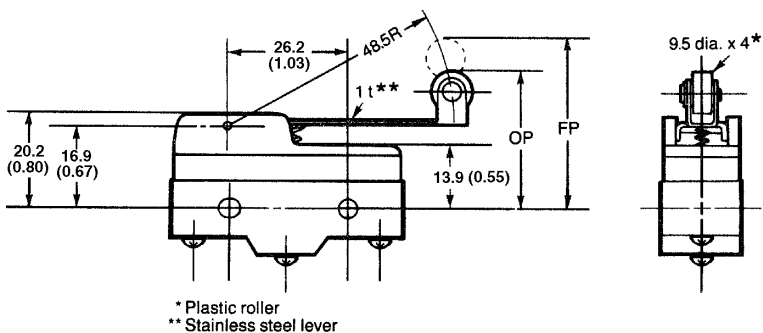

Operating characteristics	Z-15GW255-B
OF max.	130 g
RF min.	21 g
OT min.	4 mm (0.16)
MD max.	1.6 mm (0.06)
FP max.	36.5 mm (1.44)
OP	30.2 ± 0.8 mm (1.19 ± 0.03)

- Note: 1. Unless otherwise specified, a tolerance of ± 0.4 mm applies to all dimensions.  
 2. For smaller diameter mounting holes, please consult OMRON.  
 3. All drawings show the switches with screw terminals. For solder terminals, remove the "-B" from the end of the part number.

## Z-15GNJ55-B

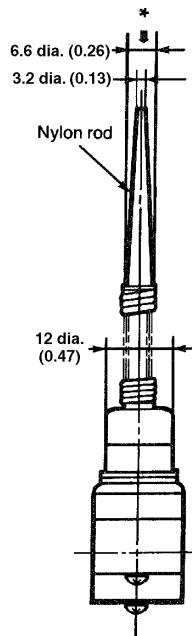
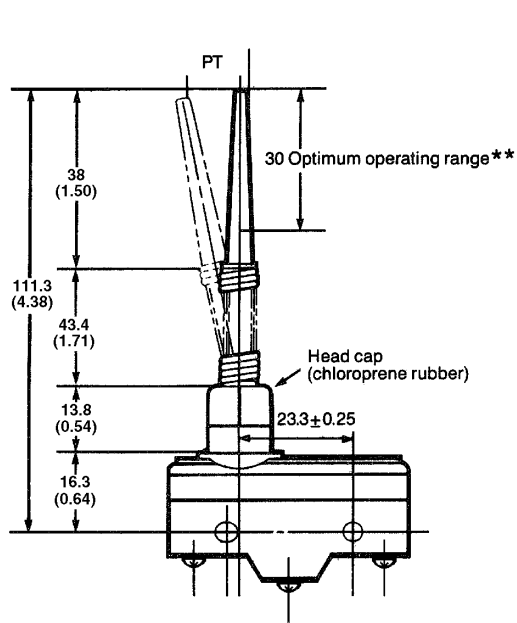

Operating characteristics	Z-15GNJ55-B
OF max.	50 g
PT max.	20 mm* (0.79)

\* Reference value

- \* The coil spring may be operated from any direction except axial direction (⚡).
- \*\* Be sure to use the cam within 30 mm from the top end of the stainless wire. (Avoid use within 80 mm from the mounting hole.)

## Z-15HNJ55-B

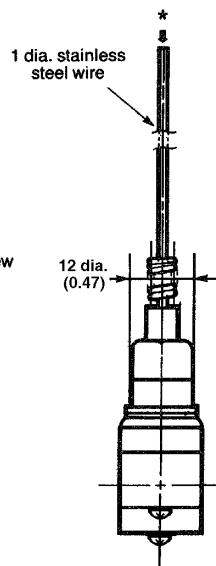
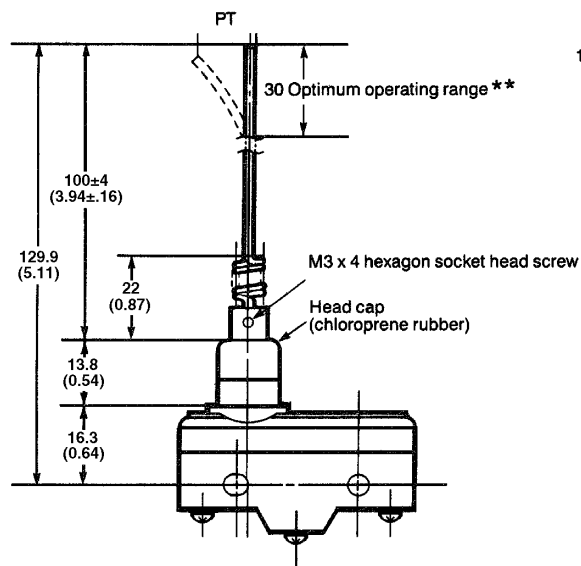

Operating characteristics	Z-15HNJ55-B
OF max.	15 g
PT max.	25 mm* (0.98)

\* Reference value

- \* The coil spring may be operated from any direction except axial direction (⚡).
- \*\* Be sure to use the cam within 30 mm from the top end of the stainless wire. (Avoid use within 100 mm from the mounting hole.)

Note: 1. Unless otherwise specified, a tolerance of  $\pm 0.4$  mm applies to all dimensions.

2. For smaller diameter mounting holes, please consult OMRON.

3. All drawings show the switches with screw terminals. For solder terminals, remove the "-B" from the end of the part number.

Unit: mm (inch)

**■ MOUNTING HOLES**

**Side mounting**

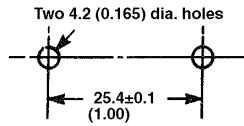

**Panel mounting plunger type**

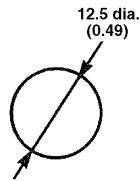

**Roller plunger type**

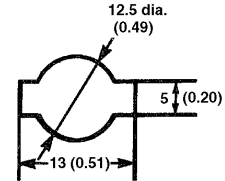

**■ TERMINALS**

**Solder terminal (blank)**

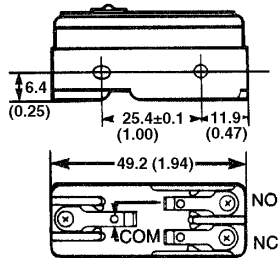

**Screw terminal (B)**

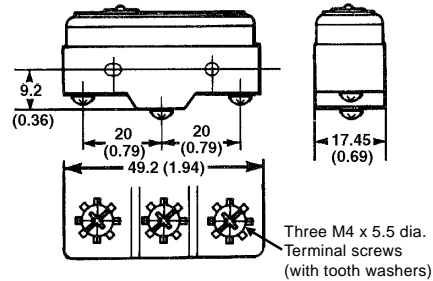

**■ MOLDED TERMINAL TYPE ORDERING INFORMATION**

The solder terminal type can be supplied with molded terminals with a choice of five different lead outlet directions. When placing your order for the molded terminal type, add the following code to the model number.

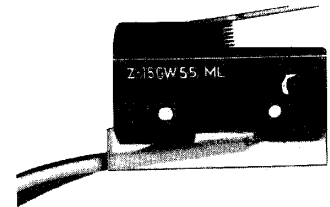
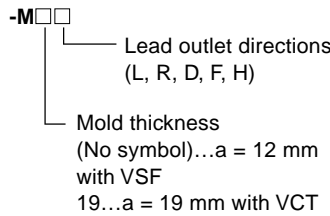

- Note:
- Standard leads are single-core vinyl cords (VSF) with a nominal cross sectional area of 1.25 mm<sup>2</sup>.
  - Standard vinyl cord lengths are 1 m, 3 m, and 5 m.
  - Mold thickness will be 19 mm when using VCT cords.
  - Standard unit has three lead outlets in the same direction.
  - Connect the black lead to the COM terminal, white lead to the NO terminal, and red lead to the NC terminal, respectively.

**■ DIRECTIONS OF LEAD OUTLETS**

The following diagrams show the molded terminal version of sealed type Z-15GW2255, with a mold thickness of 12 mm.

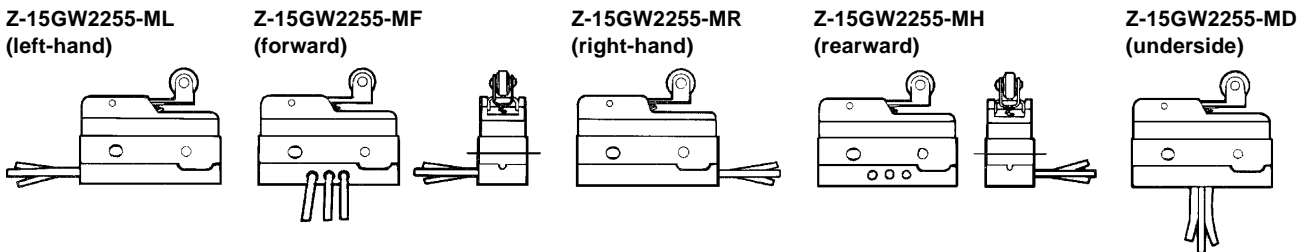

Note: Respective directions of lead outlets are determined with the plunger viewed on your left.

**■ LEAD WIRE SPECIFICATIONS**

Type	Nominal cross-sectional area (mm <sup>2</sup> )	Finished outer diameter (mm)	Connection to terminal	Length (m)
VSF (single-core, vinyl cord)	1.25	Approx. 3.1	Black-COM	0.5, 1, 2, 3, 5 (standard)
VCT (vinyl-insulated cable)		Approx. 9.6 (2-core)	White-NO	
		Approx. 10.5 (3-core)	Red-NC	

■ **ACCESSORIES**, order separately

**Hinge lever**

ZAA-1

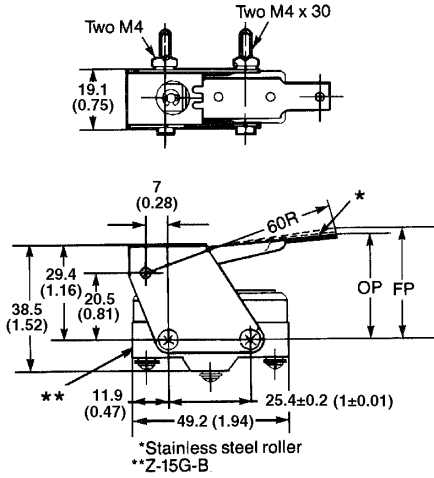

**Hinge roller lever**

ZAA-2

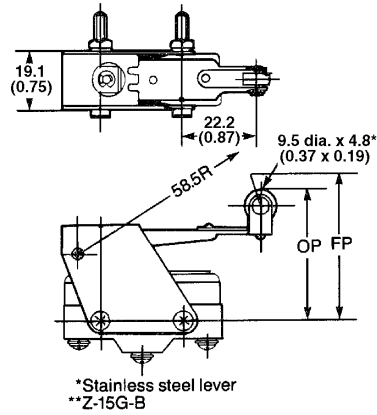

**Panel mount plunger**

ZAQ-3

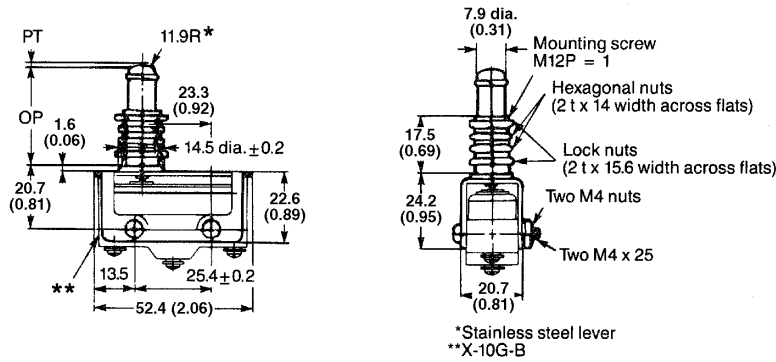

Operating characteristics	ZAQ-3 with Z-15G
OF max.	550 g
RF min.	144 g
RT max.	1 mm (0.04 in)
OT min.	4.5 mm (0.18 in)
MD max.	0.2 mm (0.01 in)
OP	27.8±1.5 mm (1.09±0.06 in)

**Panel mount plunger**

ZAQ-2

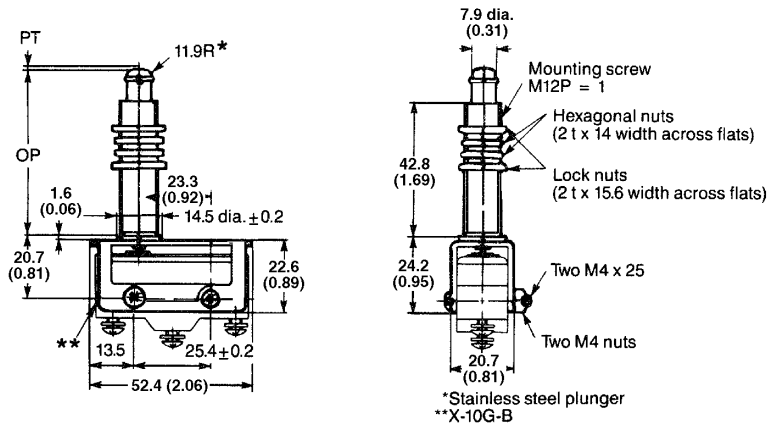

Operating characteristics	ZAQ-2 with Z-15G
OF max.	550 g
RF min.	144 g
RT max.	1 mm (0.04 in)
OT min.	4.5 mm (0.18 in)
MD max.	0.2 mm (0.01 in)
OP	53.2±1.5 mm (2.09±0.06 in)

Note: Unless otherwise specified, a tolerance of ± 0.8 mm applies to all dimensions.

**Panel mount plunger  
ZAQ-1**

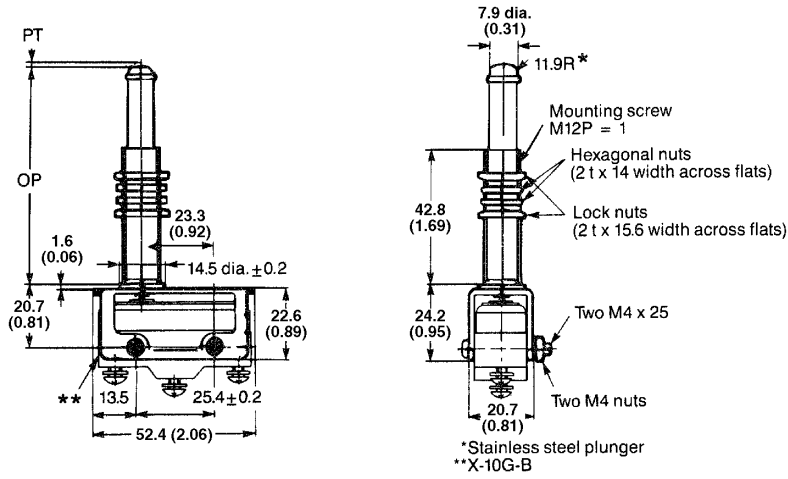

Operating characteristics	ZAQ-1 with Z-15G
OF max.	550 g
RF min.	144 g
RT max.	1 mm (0.04 in)
OT min.	20.4 mm (0.80 in)
MD max.	0.2 mm (0.01 in)
OP	69.1±1.5 mm (2.72±0.06 in)

Note: Unless otherwise specified, a tolerance of ± 0.8 mm applies to all dimensions.

**AP-A (for solder terminal)**

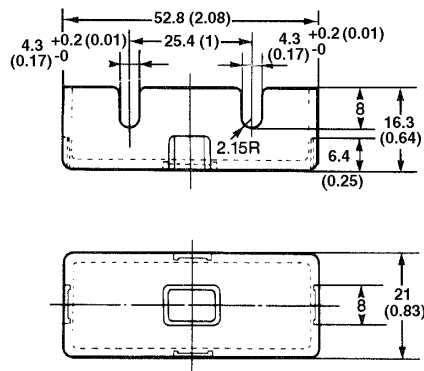

**AP1-A (for solder terminal)**

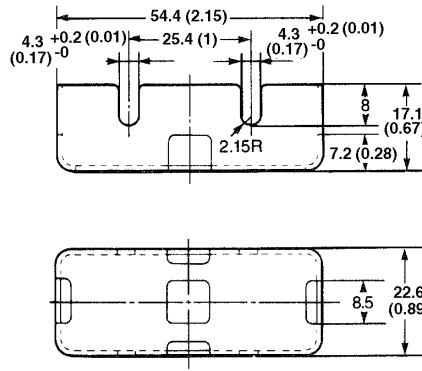

**AP-B (for screw terminal)**

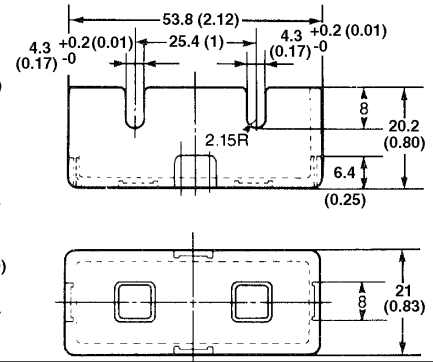

**AP1-B**

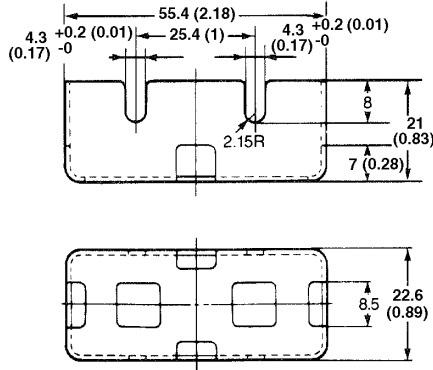

**AP-Z**

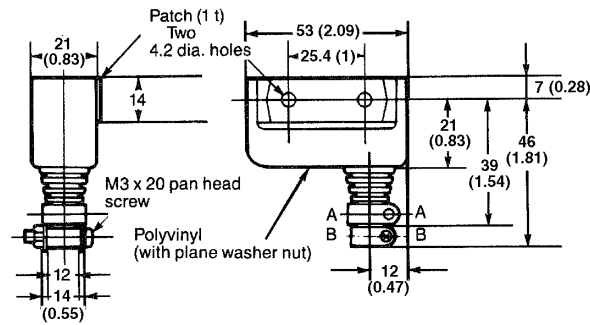

Note: Unless otherwise specified, a tolerance of ± 0.4 mm applies to all dimensions.

## ■ CABLE OUTLET DIMENSIONS

A-A section

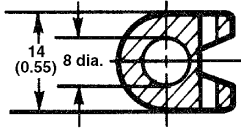

B-B section

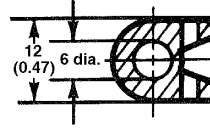

Note: The cable outlet is provided with two stepped openings (6 dia. and 8 dia.) to permit the use of either opening according to the finished OD of the cable to be connected.

## ■ APPROVALS

UL (File No. E41515)/CSA (File No. LR21642)/SEV (File No. S20/163)

Type	Rating
Z-15 Series	15 A 125, 250 or 480 VAC 1/2 A 125 VDC, 1/4 A 250 VDC 1/8 HP 125 VAC, 1/4 A 250 VAC

Note: The rated values approved by each of the safety standards (e.g. UL/CSA) may be different from the performance characteristics individually defined in this catalog.

## Precautions

### ■ MOUNTING

Use M4 mounting screws with plain washers or spring washers to mount the switch. Tighten the screws at a torque of 12 to 15 kg-cm.

Solder the lead to the terminal by applying a soldering iron rated at 60 W max. quickly (within 5 seconds). Note that applying a soldering iron for too long a time or using one that is rated at more than 60 W may degrade the switch characteristics.

#### Panel mount type (Z-15□Q)

When mounting a panel mount type switch (the one having a suffix “-Q” in its model number) to a panel, tighten the hexagon nut of the actuator at a torque of 50 kg-cm or less.

When mounting a panel mount type switch on its side, remove the hexagon nut from the actuator and carefully adjust the dog angle and operating speed because too large a dog angle or too high an operating speed may damage the switch. Especially be careful not to apply an impulsive force to the actuator when operating it. By the same token, too high an operating speed and too long an overtravel may damage a panel mount switch with a roller pin plunger.

Do not use mounting holes of the switch body when mounting on panel with M12 mounting nut.

### ■ OPERATION

#### High sensitivity switch (Z-15H)

When using the switch in a DC circuit, be sure to provide an arc suppressor as well because the small contact gap of the switch may result in contact troubles.

In an application where a high repeat accuracy is required, limit the current that flows through the switch to within 0.1 A. Also, use a relay to control a high-capacity load if the switch is connected to such a load. (In this case, the current of the relay coil is the load of the switch.)

Do not apply a force of 2 kg or higher to the pin plunger.

Exercise care that the environment conditions such as temperature and humidity do not change abruptly.

#### Drip-proof type (Z-□55)

The switch is not perfectly oil-tight; so, do not dip it in oil or water.

Depending on the environments, the materials of the rubber boots must be selected. Oil-tight, cold-resistive, and heat-resistive rubbers are available from OMRON.

#### Flexible rod type (Z-15□NJ□55) (drip-proof type)

When the rod is fully swung, the switch may operate when the lever returns, causing chattering. Use a circuit that compensates for chattering wherever possible.

Do not switch the rod to the fullest extent when the switch is to break a power circuit because such a practice may cause metal deposition to occur between the mating contacts of the switch.

---

**OMRON**

**OMRON ELECTRONICS, INC.**

One East Commerce Drive  
Schaumburg, IL 60173

**1-800-55-OMRON**

**OMRON CANADA, INC.**

885 Milner Avenue  
Scarborough, Ontario M1B 5V8

**416-286-6465**